

SECTION C-C  
SCALE 2 : 1

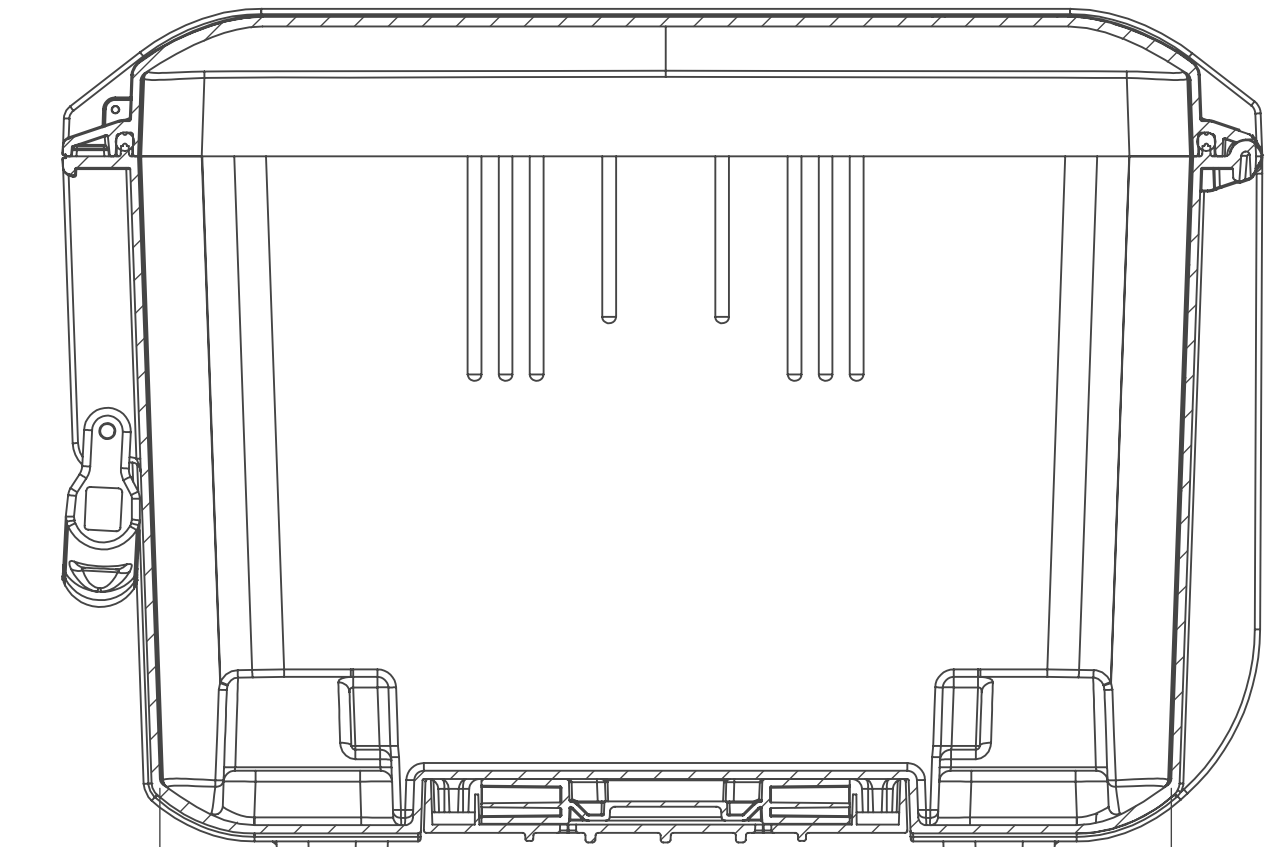

SECTION A-A

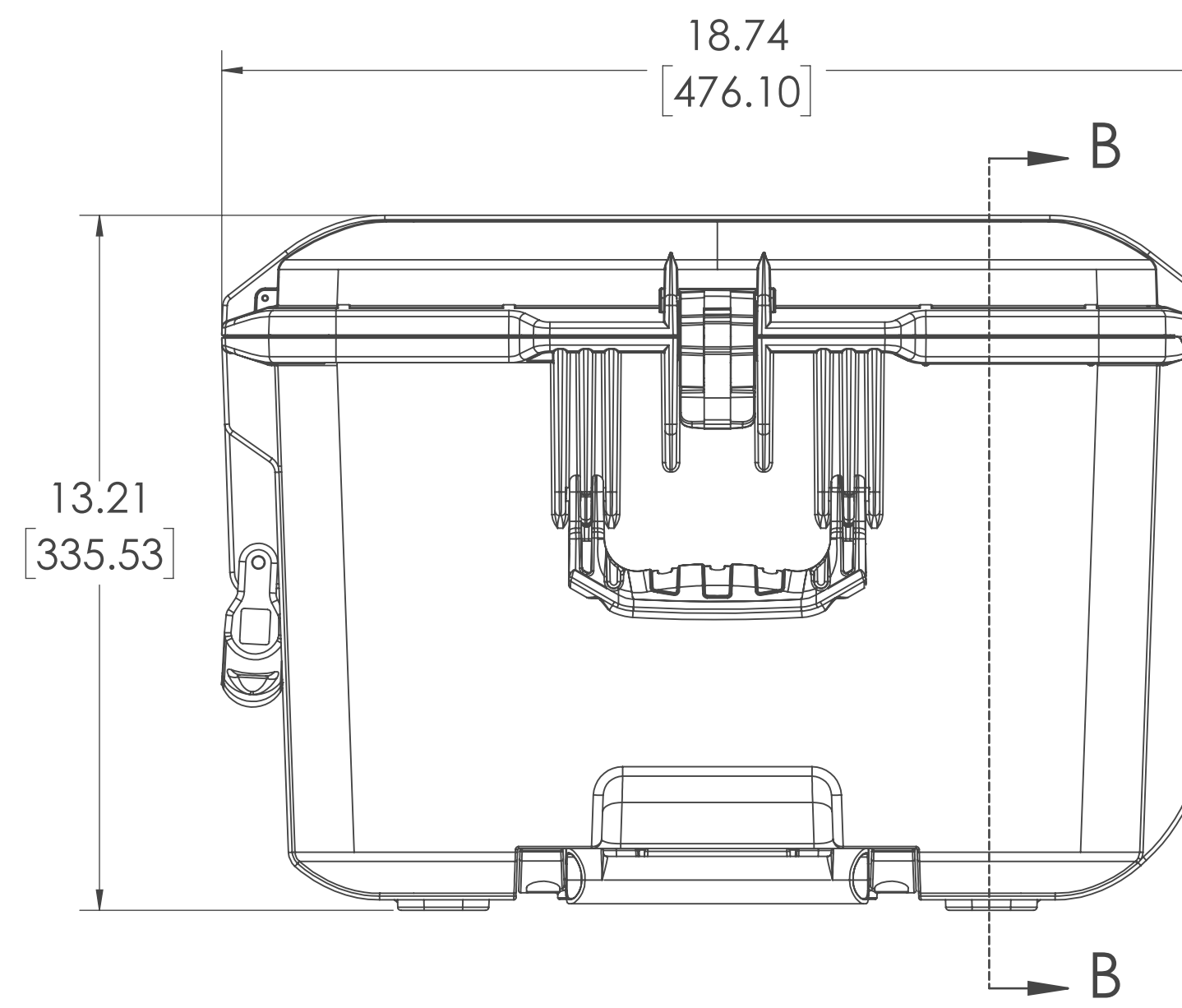
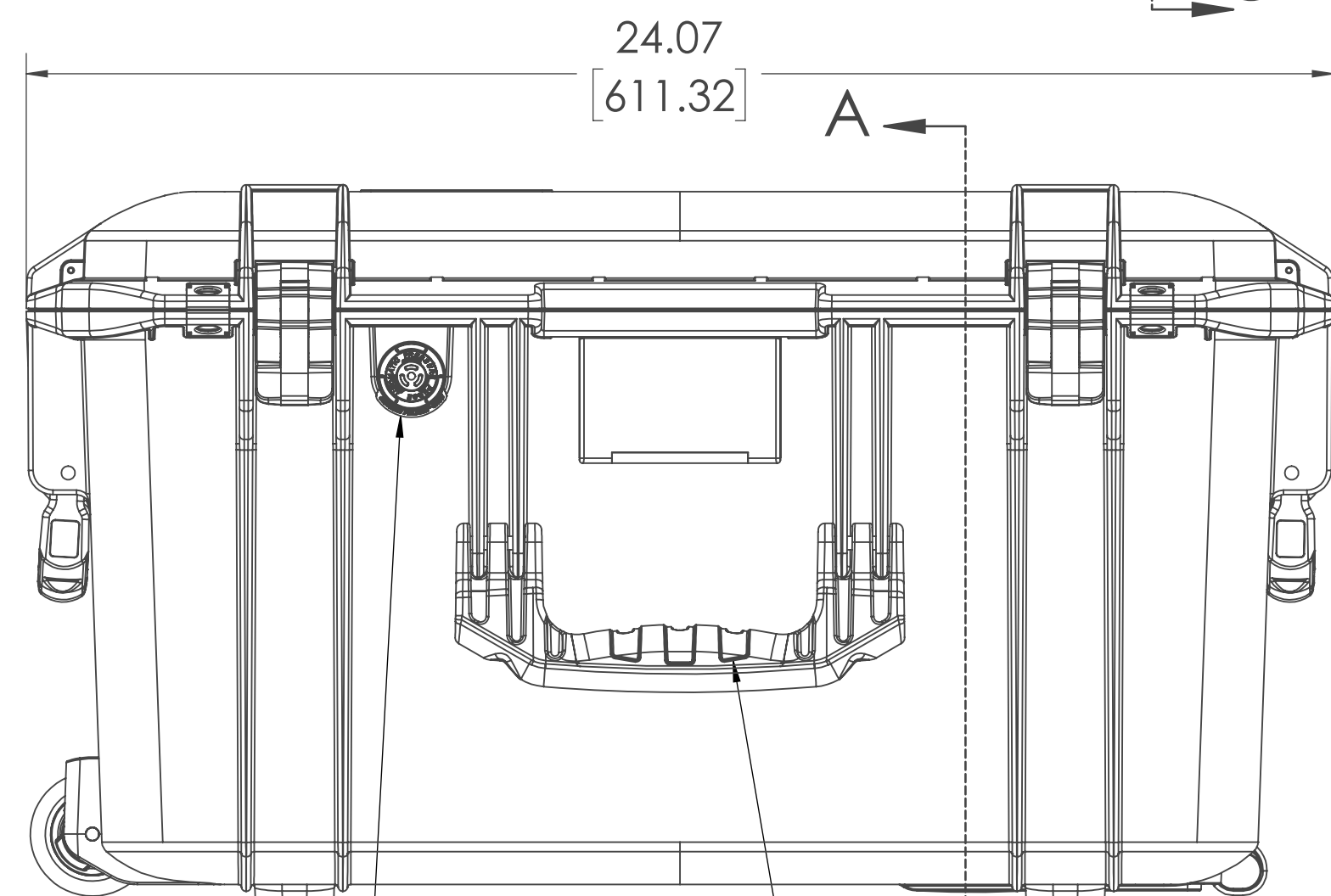
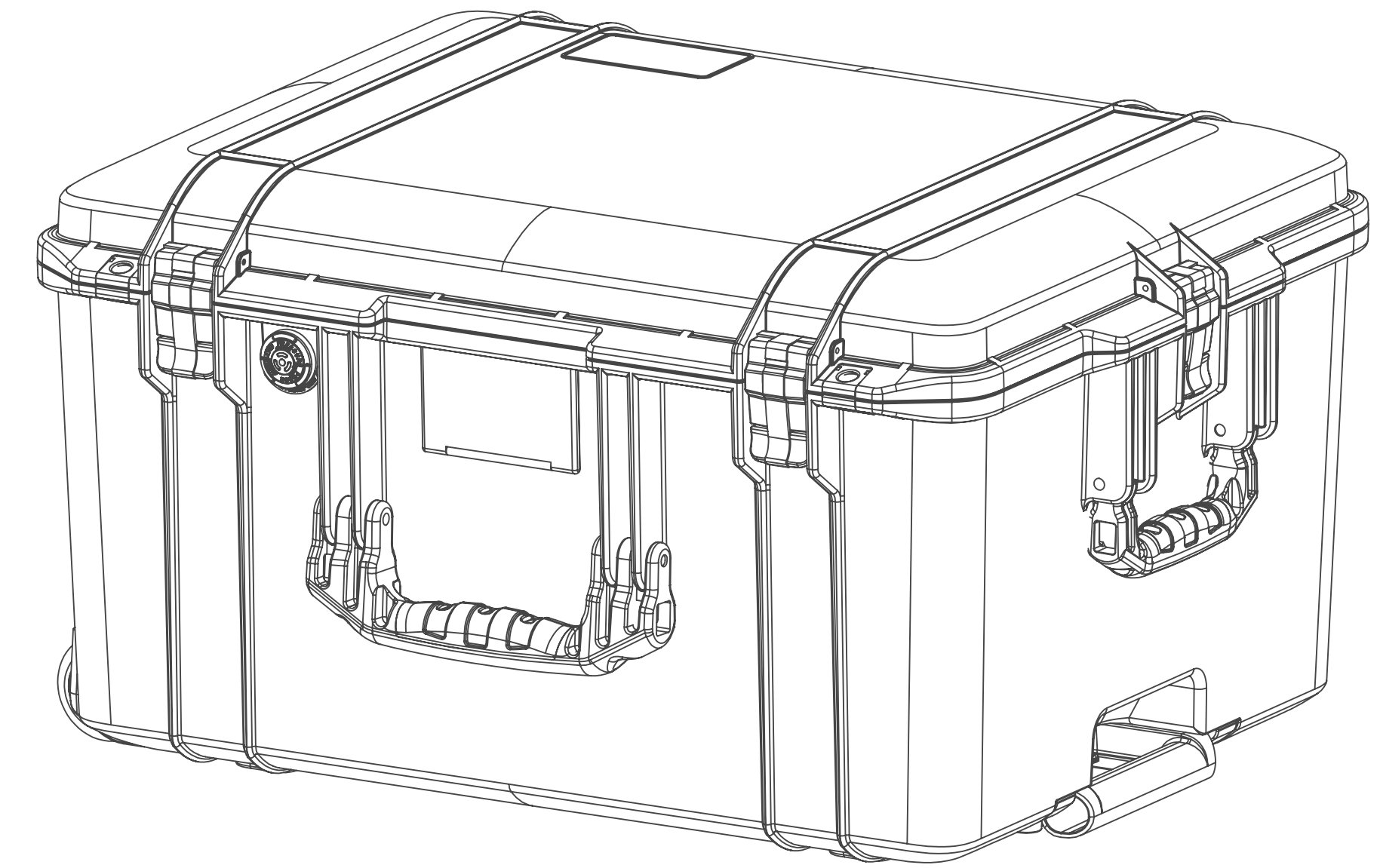
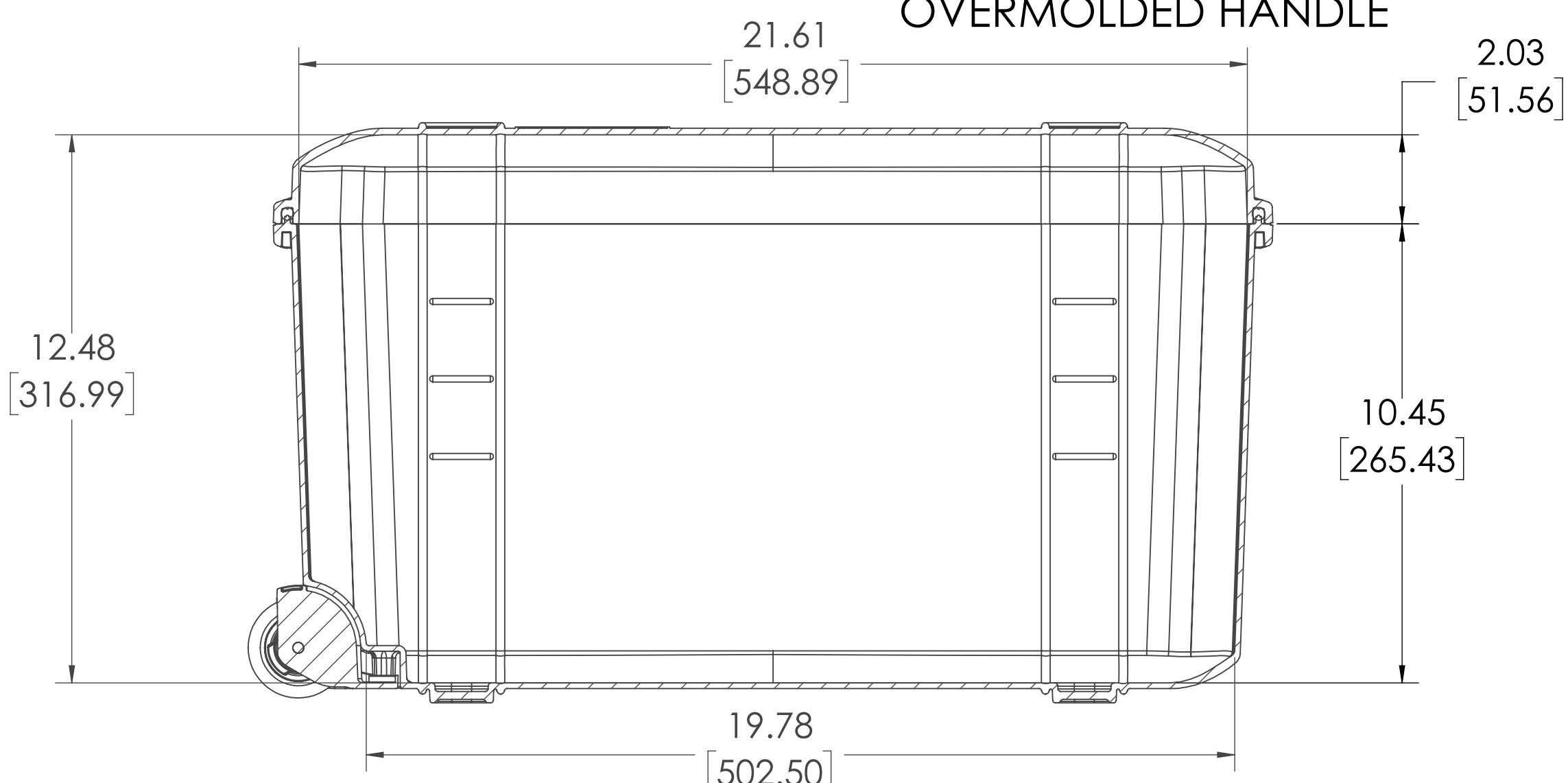

SECTION B-B

NOTES:

1. DIMENSIONS ARE FOR REFERENCE ONLY; TYPICAL INDUSTRY-STANDARD TOLERANCES APPLY
2. DIMENSIONS ARE IN: INCHES [mm]
3. REFER TO PELICAN.COM FOR CURRENT INFORMATION ON COLORS, CONFIGURATIONS, AND ACCESSORIES.



**PELICAN PRODUCTS INC.**  
DATE 2.26.19 23215 EARLY AVE., TORRANCE, CA 90505 (310) 326-4700

1607 AIR CASE  
CUSTOMER DRAWING